

Addressing a
'NATIONAL PROBLEM':

KARRI FIRE HOUSE

BY IAN WEIR AND KYLIE FEHER ARCHITECT



FIRE PROTECTION



[WORDS] NATHAN JOHNSON

AS THE NAME SUGGESTS, KARRI FIRE HOUSE IS DESIGNED PRIMARILY TO MITIGATE THE DANGER OF BUSHFIRE TO THE HOME'S OCCUPANTS. LESS OBVIOUS IS THE INTENTION OF THE ARCHITECTS TO POSITION THE BUILDING AS BOTH A MODEL FOR AFFORDABLE BUSHFIRE-RESPONSIVE ARCHITECTURE AND AS A MODEL FOR GOOD DESIGN IN LIEU OF INCESSANT VEGETATION CLEARING IN BUSHFIRE-PRONE AREAS.

Designed for a professional fire-fighter and his family, and sited in a magnificent eucalyptus diversicolor forest in Denmark, WA, Karri Fire House is a collaborative project by research architect Ian Weir Architect from the University of Queensland and Kylie Feher Architect.

It is designed to achieve Bushfire Attack level (BAL)-40 construction according to AS3959 - Construction of buildings in bushfire-prone areas, and on a budget of \$2,900 per sqm. Incidentally, Weir notes that the major success of the project is the reconciling, through architecture, the otherwise opposing management goals of bushfire safety and biodiversity conservation.

"Increasingly, bushfire regulators, authorities and local governments are encouraging – if not enforcing - vegetation clearing above building design as the principle means of bushfire risk mitigation," he explains.

"Design innovation is further hamstrung by misconceptions within society that building to the AS3959 bushfire standards is cost prohibitive. Of greater concern is that worldwide, biodiversity conservation is viewed as a management goal that is in direct opposition to bushfire safety."

"The Karri Fire House purposefully challenges these misconceptions. It does so by presenting an inexpensive means of achieving BAL-40 construction, which in turn minimises its direct (and indirect) environmental footprint."

Had Weir and Feher built to the lower BAL levels they would have had to clear double the area of vegetation and put in place an active management of that area to maintain the lower bushfire exposure to a less resilient house. Regulators have anecdotally said this approach is problematic given that such large-scale vegetation management is difficult to police and often never maintained.

Instead, with the BAL-40 Karri Fire House, risk mitigation is achieved through resilient design rather than an active response to bushfires, like a landscape management plan.

FIRE PROTECTION



1 The Galvabond and Heritage Galv walls and roof are cost effective bushfire resilient solutions that comply with AS3959 BAL-40. They also weather to a non-reflective texture (unlike Zinalume) and match the granite outcrops and Karri tree trunks

2 The 1,400sqm steeply sloping site is immediately adjacent a nature reserve on the Bibbulmun Track and is dominated by magnificent Karri's amongst granite outcrops and features a vegetation conservation corridor on the downslope from the house

3 The aesthetic objective of 'light resilience' is expressed through contrast – with rock-anchored heavy masonry walls – from which spring the shop-fabricated structural steel cantilevered frame

4 Modwood BAL-40 'Flamesheid' decking was used on the home's veranda

THREE LINES OF DEFENCE

1. Spandek galvanised steel cladding
2. Firefly non-combustible sarking
3. Rockwool insulation batts

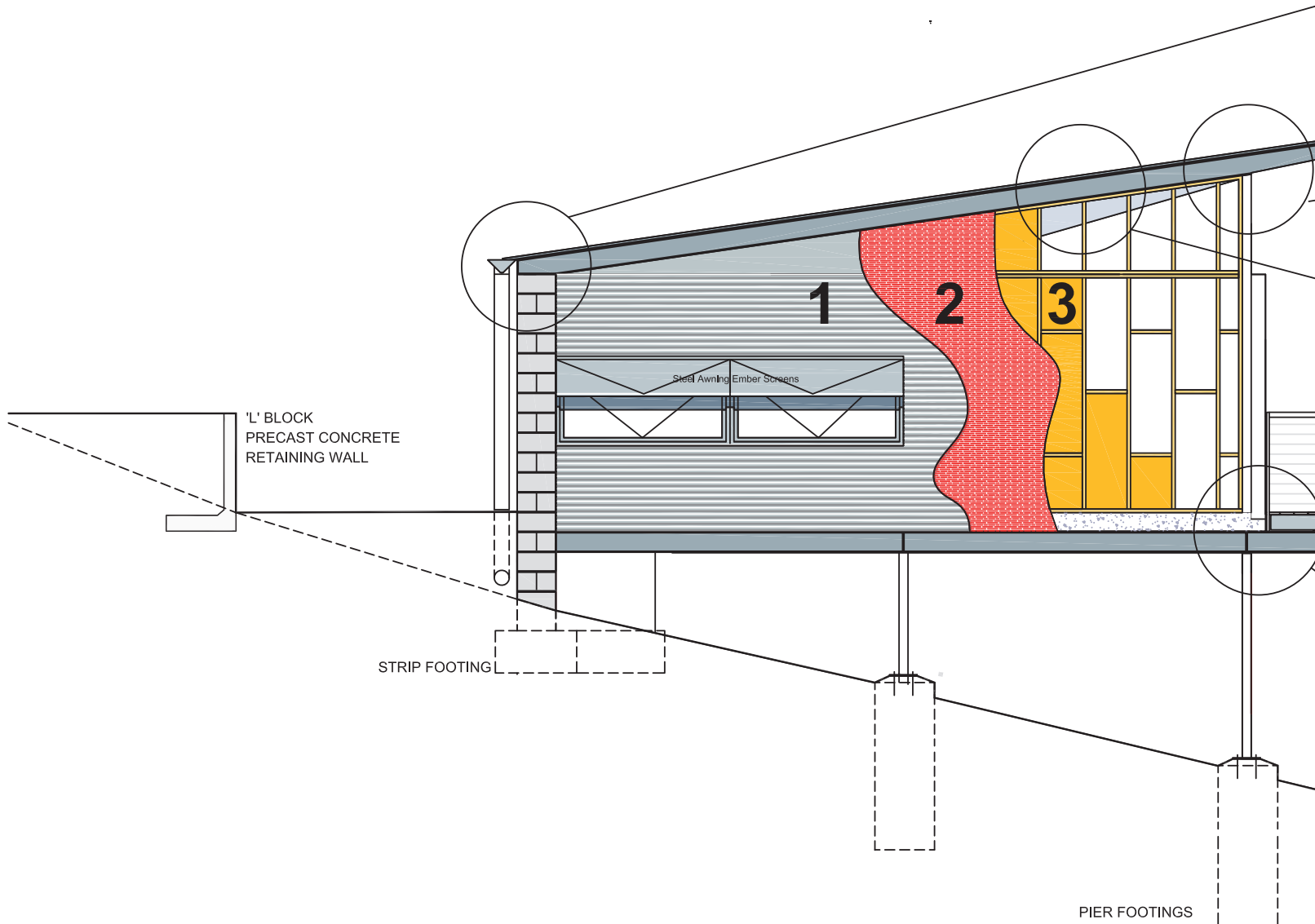

FIRE PROTECTION

EASY CLEAN GUTTERS

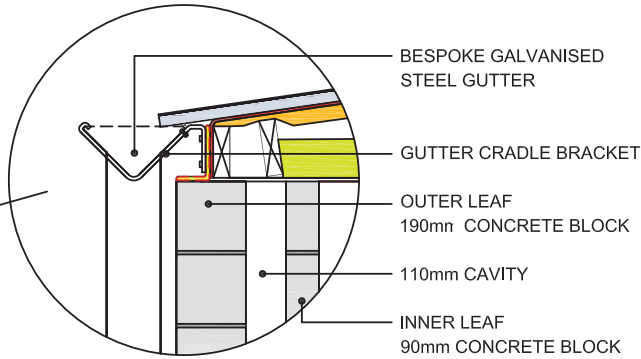

EMBER SHIELDED EAVES

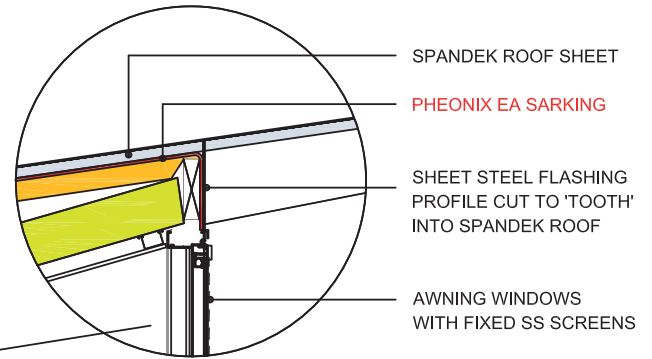

THERMAL MASS

FIRE-PROTECTED ROOF SPACE

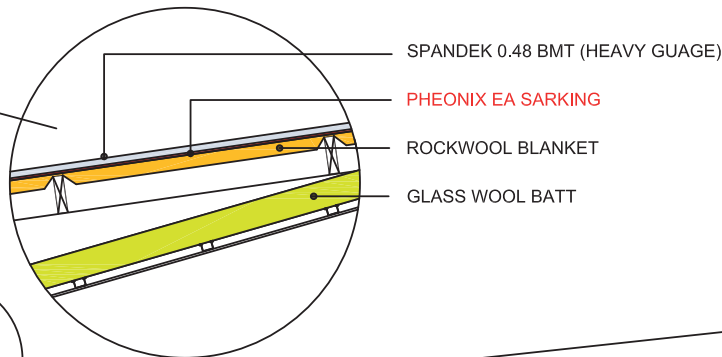

BAL-40 VERANDA

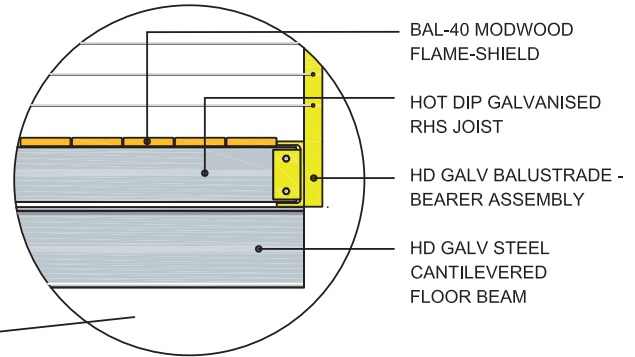

EMBER-PROOF
DOOR THRESHOLD

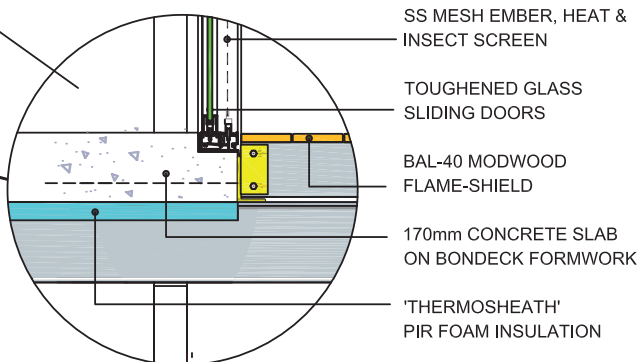

FIRE PROTECTION



THE INTERIOR FITOUT WAS DONE ON A BUDGET OF LESS THAN \$3,000 PER SQM

The architects adopted a multi-modal design approach that included landscape design, architecture, and industrial design to address what they call a “significant national problem that is beyond the scope of conventional modes of architectural practice.”

“We believe that developing a particularly Australian response to habitation of our bushfire ecosystems is dependent as much upon good design as it is on good science,” says Weir.

Much of Karri’s bushfire performance is owed to the industrial design of architectural components and the integration of technologies and materials from commercial construction and fire fighting apparel.

The building products were chosen for their low-combustibility and fire resistance, however the product choice and passive design of the building also marries with the client’s cross-purposed goal for an energy efficient and bushfire resistant home.

As is the case with most extreme bushfire-prone areas around Australia, Karri’s site is typically cold in winter and hot in summer. In response, the architects integrated fireproof cavity masonry walls and a suspended concrete floor (with fireproof insulation) to provide the necessary thermal mass for the winter seasons, while summer heat and glare is moderated by external shutters, the verandah overhang, and, importantly, the [mostly untouched] Karri forest itself.

The building’s heavy masonry walls are rock-anchored and support a shop-fabricated structural steel cantilevered frame. The frame is wrapped by galvanised sheeting on its exterior sides and top which aesthetically reflects the texture of the granite outcrops and the Karri trees but also, more literally, the radiant heat of bushfire. This steel shield also overlays one of the most interesting building materials used in Australia - an envelope of fire-proof sarking adapted from fire-fighter’s tunics which provides a second line of fire defense.

Karri’s bushfire shutters are a major component of the building and were designed by Perth

window-manufacturer Stephen Ripamonti. Weir notes that the entire spatial planning of the house links the daily pattern of life to the performance of the shutters which slide between full and half-width.

With help from a site survey by Denmark Survey and Mapping and in collaboration with energy consultants (Architecture-Collective) and structural engineers (Westera Partners), Weir and Feher have created a bushfire responsive home which has been completed for less than \$3,000 per sqm for the internal enclosed areas.

While Karri has all the characteristics of the sustainable detached houses we see around Australia, like solar panel and heat pump systems, and no mechanical heating or cooling, Weir says the most important lesson from Karri in terms of sustainability is that it focusses on conserving biodiversity in the first place.

Karri Fire House presents a model for how the otherwise opposing goals of biodiversity conservation and bushfire safety can be reconciled. It also addresses misconceptions that building to high bushfire standards is cost prohibitive. ■

FIRE PROTECTION



PEOPLE: ARCHITECTS KYLIE FEHER & IAN WEIR **STRUCTURAL ENGINEER** WESTERA PARTNERS **ENERGY CONSULTANT** ARCHITECTURE-COLLECTIVE **INDUSTRIAL DESIGN (BUSHFIRE SHUTTER SYSTEM)** STEPHEN RIPAMONTI **PHOTOGRAPHY** IAN WEIR & ANDREW HALSALL

PRODUCTS: **ROOFING** FIELDERS, 'HERITAGE GALV' SPANFORM PROFILE (0.48MM BMT) **EXTERIOR WALLS** FIELDERS, 'HERITAGE GALV' SPANFORM PROFILE (0.42MM BMT), BLUESCOPE 'GALVABOND' FLAT SHEET (0.8MM BMT), BORAL MASONRY CONCRETE BLOCK **STRUCTURAL STEEL** BLUESCOPE, HOT DIP GALVANISED STEEL BY M&A **STEEL FLOOR** BLUESCOPE BONDECK WITH 190MM SLAB **INTERNAL WALL FRAMING** PINE STUD FRAME **SARKING** FIREFLY PHEONIX EA **INSULATION** ROCKWOOL (ROOF AND WALLS) **DECKING** MODWOOD BAL-40 'FLAMESHEILD' **WATER HEATING** HEAT PUMP SYSTEM **FIRE-FIGHTING WATER SUPPLY** 45,000L TANK WITH 5HP HONDA WATER PUMP **GLAZING** SHELLEY GLASS, TOUGHENED GLASS, **COMMERCIAL SLIDING DOOR SYSTEM** EMBER/ RADIANT HEAT/FLYSCREENS DENMARK WINDOWS, ALUMINIUM SLIDING DOOR SYSTEM WITH STAINLESS STEEL MESH