



ModWood New Zealand

Technical and Installation Guide

These guidelines should be read in conjunction with the New Zealand Building Code (NZBC). Clauses that apply to open, slatted decking and balcony construction are:

- B1 Structure
- B2 Durability
- D1 Access routes
- E2 External moisture (waterproofing to the building envelope)
- F2 Hazardous building materials (glass barriers)
- F4 Safety from falling

When building a deck please refer to the following standards: AS/NZS 1170, NZS 3602, NZS 3603, NZS 3604, NZS 3605, NZS 3640 and NZS 4203. Other recommended references include BRANZ Build 139 Supplement: Timber Decks. Any deck or balcony 1.5 metres or more above cleared ground level requires a building consent. However, even if a building consent is not required, construction must still comply with NZBC requirements.

Fixings and Fastenings

Hot dip galvanised steel nails and screws may be used to fix decking (NZS 3604:2011 Table 4.3), but note 4 states, that where timber has been treated with ACQ or CuAz preservative, minimum type 304 stainless steel or silicon bronze fixings must be used and that stainless steel nails should be annular grooved to provide sufficient withdrawal resistance.

Install *ModWood* decking with a 12 mm minimum gap between the building cladding and the decking for drainage and maintenance.

Corrosion zones

- In zone B use of hot dipped galvanised fixings when installing *ModWood* is possible as long as the requirements of NZS 3604:2011 Tables 4.1 and 4.3 are met.
- In zone C use of stainless steel (minimum grade 304) is a conservative decision which we recommend, however should you decide to use hot dipped galvanised steel fasteners when installing *ModWood* the requirements of NZS 3604:2011 Tables 4.1 and 4.3 must still be met.
- In Zone D & E, table 4.1 requires all structural fixings in sheltered and exposed locations to be stainless steel (minimum grade 304)

Slip resistance

- In public areas, it is recommended that *ModWood* decking be laid at right angles to the main direction of pedestrian traffic.
- A water absorbing mat may be necessary around swimming pool surrounds, pool ramps and stairs leading to water.
- Standards Australia HB 198:2014 Table 3B provide guidance for pedestrian surfaces for particular applications
- *ModWood* 137mm has a slip resistance classification of R11 rating
- *ModWood* has also been tested to the Dry Floor Friction Slip Resistance Test AS 4586:2013 and achieved a classification of D1 with a mean coefficient of friction of 0.6 which meets the criteria of D1

Safety from falling

When installing stairs, elevated decking that may require handrails and/or balustrading then you will need to consult with a suitably qualified engineer on the regulatory safety requirements in these circumstances.

EXTERNAL STAIRS on the access route into a house may provide access to a deck or across a sloping site. If they are part of the main access route to the house, they must comply with NZBC clause D1 Access routes.

The Acceptable Solution D1/AS1 is quite prescriptive, including requirements for stair pitch, riser height, tread depth, projections or nosing's, where open risers may be used, stair width, handrails and slip resistance.

Deck Barriers

Information that needs to be considered, if you are building a deck or ramp where someone could fall vertically one metre or more then you must comply with NZBC Clause F4. In 2012, the Department of Building and Housing (now Ministry of Business, Innovation and Employment – Building and Housing) published Guidance on barrier design, which gives guidance and recommendations on designing and installing Building Code-compliant barriers.

As of December 2012, a timber barrier complying with paragraph 4.2.7 of the Guidance on barrier design meets the Building Code clause F4 and B2 requirements. Other barriers will need specific engineering design.

Barrier elements-

Barriers for residential decks must:

- be continuous where the fall height is over 1.0 m
- be at least 1.0 m high
- have openings that prevent a 100 mm diameter sphere passing through
- have less than 15 mm gaps between horizontal rails
- have the top of the barrier at least 760 mm above a fixed seat
- have no sharp edges or projections.

Care and Maintenance

This document can be reviewed on the *ModWood* website.

ModWood is CodeMark New Zealand certified, Certificate Number CM70070 and it:

- proves it meets Building Code performance requirements
- ensures its is capable of performing as intended
- streamlines the building consent and inspection process

CodeMark is unchallengeable and has legal status equivalent to that of an Acceptable Solution or Verification Method. Building consent authorities (BCAs, usually councils) must accept a CodeMark certified product as complying with the New Zealand Building Code when it is used in building work, as long as the product is specified for use in accordance with the certificate.

A copy of the CodeMark Certificate, can be down loaded off the *ModWood* website.



The Sustainable Alternative

Fixing Instructions for ModWood as Screening

The following information provides guidance on installation for screening and fencing applications. Please note *ModWood* is designed for cosmetic screening not barrier or rail applications. As we cannot cover

all situations should you have any specific questions with regards to your installation please contact *ModWood* directly.

	68x17mm	88x23mm	137x23mm
Number of fasteners per upright	♦1	2	2
a Continuous (mm)* Centre to centre span (ModWood installed on edge)	800	1500	1500
b Single (mm)* Centre to centre span (ModWood installed on edge)	800	800	800
c Centre to centre span (ModWood installed on flat) (mm)	250	450	450
d Minimum clearance from wall (mm)*	45	45	45
e Minimum side by side gap (mm)*	8	8	8
f Boards installed vertically* - max. distance between rails (mm)	800	1500	1500
g Minimum ground clearance (mm)	150	150	150
h Minimum clearance at board end from fixed structure (mm)	6	6	6
i End butt gap (mm)	2	2	2
j Maximum overhang (mm)	25	50	50

♦Single span use 2 fasteners

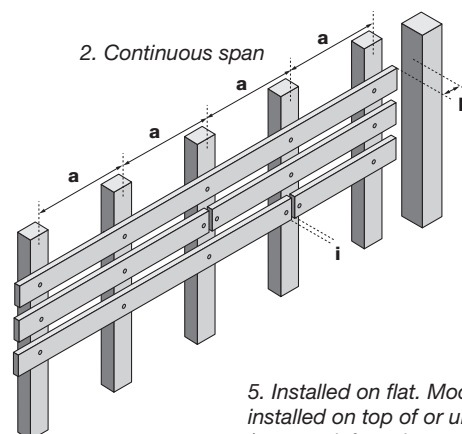
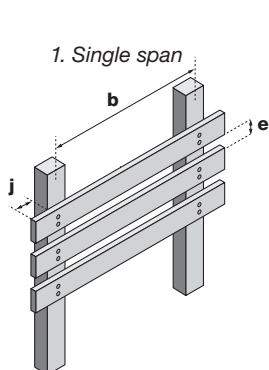

3. Installed vertically

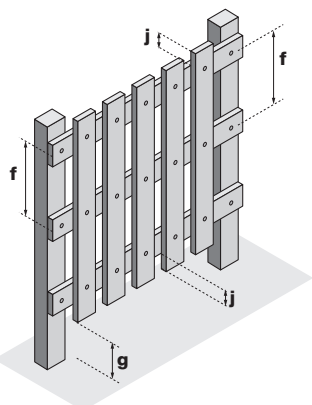

4. Installed close to wall

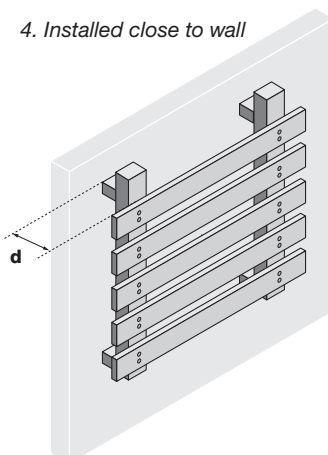

5. Installed on flat. ModWood can be installed on top of or under the frame. (ensure sub frame is adequately engineered)

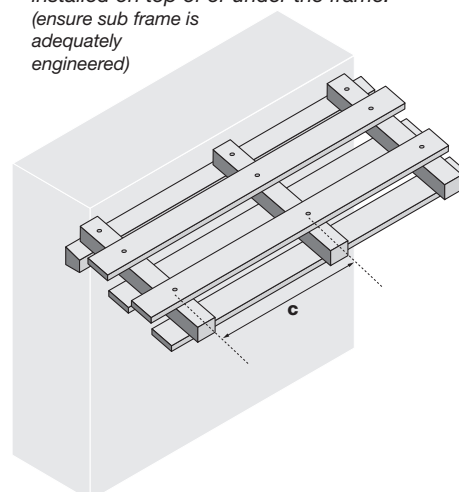

The Sustainable Alternative

Typical Fastenings used with ModWood

Up to 23 mm thick boards

Fixing to timber	- 8G-10 x 50 mm countersunk head screws - 2.8 mm x 50 mm dome head [^] twist shank nails
Nail guns [^]	- C2.5 x 52 Dome R SS Coil Nails (Ring shank for softwood) - C2.5 x 52 Dome S SS Coil Nails (Screw shank for hardwood)
Fixing to steel	- 10G-10 x 40 mm SDS (Self Tapping Tek) screws - non wing tek

Check that fastener is suited for the site conditions.
Nail gun not preferred method.

ModWood Thermal Expansion Properties – Fixing tip

The temperature of a *ModWood* board sitting in full sun for a length of time is approx. 20-25°C warmer than the ambient air temperature.

As *ModWood* expands in heat and sun, to avoid building stress into your screen and having possible lengthways shrinkage, it is best to fix your screening boards when the ambient temperature is less than 25°C and when the boards are not sitting in full sun (see “coefficient of thermal linear expansion” on our website.) It is important not to leave boards laying in full sun for long periods of time prior to installation. Conversely fixing screening boards in ambient temperatures significantly colder than the average mean temperature for your region may lead to increased deflection during warmer periods.

ModWood Installed with KlevaKlip Concealed Fixing System

ModWood must not be installed over head with KlevaKlip i.e. ceiling or soffit applications.

*If *ModWood* is installed using the *KlevaKlip* concealed fixing system this allows a 4 mm side by side gap which is acceptable provided:-

- minimum clearance from wall must be at least 150 mm and the upright span must be reduced to 800 mm centres for continuous or single span installations.

Maximum height of the screen from ground level if *KlevaKlip* system used is 2400 mm.

Where butt joints are required with *KlevaKlip* system - doubling the posts and clips are required at these points.

Refer to *KlevaKlip* website for fixing and adhesive instructions:
www.klevaklip.com.au

[^] Do not use nails for 137 mm board

General

- When fixing, ensure that you start from one end and then fix progressively along the board length. This will ensure that you aren't building stress into the board, which may occur if you fix off the board ends first and then fix off the intermediary posts.
- Pre-drilling and countersinking is always essential.
- Fixing too close to board end will cause splitting - no closer than 15 mm and no closer than 20 mm from edge. Do not overdrive fasteners.
- The hole drilled must be slightly greater than the 'outside diameter' of the screw thread.
- Screw down with low torque, take particular care at ends of the boards.
- Ensure the head of the screw finishes flush with board surface.
- Fasteners in low corrosion areas must have galvanised coating or equivalent. In high corrosion areas use stainless steel fasteners.
- Fasteners must be installed perpendicular to the board face i.e. do not skew fix.
- Use only fixings which comply with New Zealand Standards
- *ModWood* must not be used as part of the frame or used as a structural element.
- *ModWood* can be installed overhead so long as it is face fastened with screws.

Vertical Upright (post)

Uprights must be rigid and fixed at base eg. min 65 x 65 mm steel or 90 x 90 mm timber.

Do not use *ModWood* for the upright.

Posts must be installed perpendicular, parallel and square to each other - and must have sufficient rigidity to remain so during service.

Note: Footings should be as per local council regulations.

Please note:

Due to the moisture normalisation of the wood fibres in the product, *ModWood* screens can in some circumstances show some deflection between the uprights.



The Sustainable Alternative

Fixing Instructions for ModWood Flame Shield®

Storage and handling

Store ModWood in a flat, dry area under roof and off the ground. Always carry ModWood on edge.

Ventilatizon

Good ventilation for your deck is essential. Check our chart for ground clearance information. Do not prevent airflow by sealing off deck ends, for example with garden beds, trees or solid objects.

Installation

Fixings must not be closer than 15 mm from the end of the board and do not skew fasten. Double fix on each joist. Fasten 20mm from outside edge of the board. When butt joining top fix boards it is recommended to have 45 mm joists. Stagger joints –do not create a seam of joints.

Screw fixing

Pre-drilling and countersinking is essential when fixing with screws. Drill-bits used must be at least the outside diameter of the screw thread (preferably slightly oversize). As a minimum, galvanised coated screws are recommended for low corrosion areas. Use stainless steel screws for high corrosion areas. Screw down with low to medium torque. Do not 'overdrive' screws, particularly near the ends of the boards. Screws should finish 'flush' with top of board.

Nail fixing

Pre-drill with a drill-bit large enough to provide a slight clearance on the shank, then fix with a dome-head galvanised nail. Do not punch the nail heads under the surface. In high corrosion areas, we recommend stainless steel decking nails (pre-drilling a hole with clearance is still required).

Nail Guns

As with all decking, the preferred methods of fixing are drill and screw, or drill and nail. Should you decide to use a nail gun, you need to satisfy yourself that nail penetration and retention is satisfactory. Such tests should be carried out prior to installation. The preferred nail gun is the Paslode Duo-Fast CNP 65 Coil Nailer. Use dome head stainless steel decking nails. Double fix on each joist. We do not recommend nail guns for on decking greater than 23 mm thickness, or for use on steel joists.

When fixing boards by nail gun, pre-drilling and hand nailing is essential for each fastener within 50 mm of the end of a board.

Concealed Fixing with ModWood

KlevaKlip is the preferred method of using concealed fixing with ModWood. For all information on *KlevaKlip*, please contact: www.klevaklip.com.au

Please note that when using concealed fixing products, it is still important to ensure that the ModWood standard gap spacings for side-by-side, butt-joints, and end spacings are still strictly adhered to.

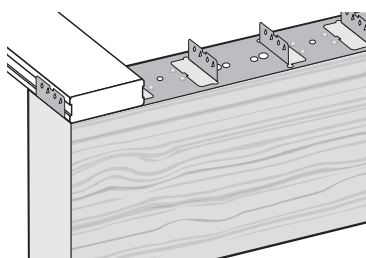

Important please check you use the correct model *KlevaKlip* to fit the chosen ModWood board. Refer overleaf.

Flame Shield®, is certified to AS1530.8.1-2007 with a BAL-40 rating. *Flame Shield*® can be used in bushfire prone areas that have a bushfire attack level (BAL) up to and including BAL-40 (AS 3959-2009). *Flame Shield*® certification allows for the sub-floor space to be either enclosed or un-enclosed. (Please refer to ModWood ventilation requirements). *Flame Shield*® boards must not overhang or be cantilevered past the joist at any point.

The sub-frame joists and bearers need to be constructed from non-combustible materials or one of the bushfire-resisting timbers (refer to AS3959-2009 see Appendix F) which as at December 2011 includes Spotted Gum, River Red Gum, Blackbutt, Silvertop Ash, Red Ironbark, Merbau, Turpentine. With this construction system, Flame Shield has been certified to comply with AS1530.8.1 Section 8 Construction for Bushfire Attack Level 40 (BAL-40).

Flame Shield® is manufactured to R11 (AS/NZS 4586:2013).

Flame Shield® has an ink jet message repeated at approx.1000 mm intervals along its edge "Flame Shield BAL-40, AS1530.8.1". This message should be sighted on each board prior to installation. It is also highly recommended that a copy of AS3959-2009 be obtained prior to construction in bushfire-prone areas. A copy of this standard can be purchased from SAI Global.

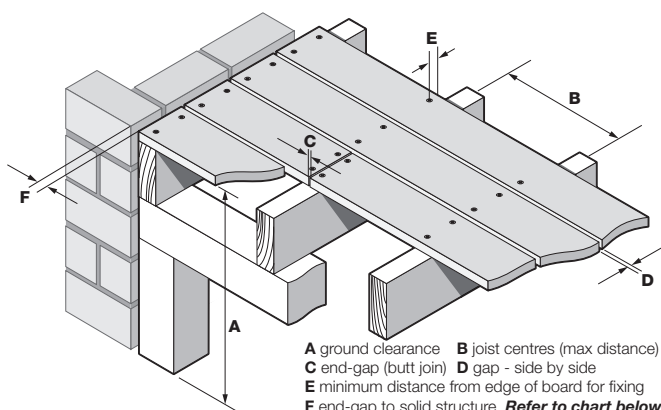

ModWood Fixing Specifications

Dimensions	Decking width (mm)
	137x23 mm
A minimum ground clearance	300
A minimum clearance over concrete	50
B joist centres (max distance)	450
C minimum end-gap (butt joint)	2
D minimum gap - side by side	4
E minimum distance from edge of board for fixing	20
F minimum end-gap to solid structure	4
screws (pre-drill and countersink)	yes
dome-head nails (pre drill)	yes
nail gun acceptability *	yes
suitability for fixing to steel substructure	refer to website
fixing over concrete	refer to website

* Use only dome-head nails from "coil-nail" gun. Pre-drill and hand nail when within 50 mm of end of board. Not our preferred fixing method.* Do not use nail gun within 50 mm of end of board.

In all cases, when screwing down do not overdrive screws. Fix with low to medium torque. Do not punch nail-heads under surface of board. Fixing too close to the end of the board will cause splitting. DO NOT fix within 15 mm of end of board.



The Sustainable Alternative

ModWood Thermal Expansion Properties – Fixing Tip

The temperature of a *ModWood* board sitting in full sun on a warm to hot day for a length of time is approx. 20-25°C warmer than the ambient air temperature. As *ModWood* expands in heat and sun, to avoid building stress into your deck and having possible lengthways shrinkage, it is best to fix your decking boards when the ambient temperature is less than 25°C and when the boards are not sitting in full sun (see 'coefficient of thermal linear expansion' on our website).

ModWood Decking Spacers

ModWood decking spacers, as seen below, have been developed to make your installation easier, and in line with *ModWood* fixing instructions. Note: Every pack of *ModWood* comes with 10 free spacers (used as strapping holders on the corners of full packs). Extra spacers are available from your local *ModWood* retailer, or by contacting the *ModWood* distributor in your state.

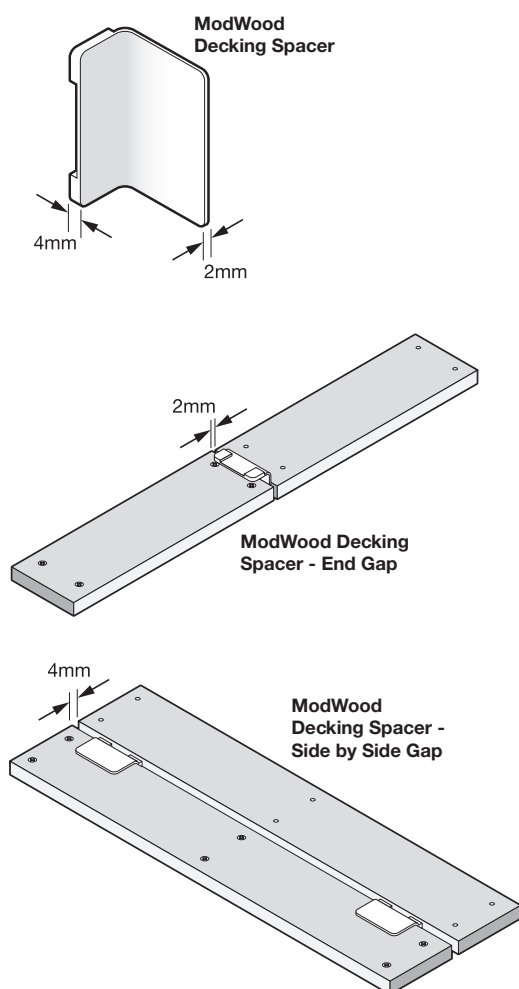

Typical Fastenings used with ModWood

Up to 23 mm thickness boards

Fixing to timber - 8G-10 x 50 mm countersunk head screws
- 2.8 mm x 50 mm dome head twist shank nails

Nail guns

- C2.5 x 52 Dome R SS Coil Nails
(Ring shank for softwood joists)
- C2.5 x 52 Dome S SS Coil Nails
(Screw shank for hardwood joists)

Fixing to steel - 10G-10 x 40 mm SDS (Self Tapping Tek) screws - non wing tek

General

- **Pre-drilling and countersinking is essential**
- **Fixing too close to board end will cause splitting – no closer than 15 mm and no closer than 20 mm from edge. Do not overdrive fasteners**
- The hole drilled must be slightly larger than the 'outside diameter' of the screw thread or nail shank
- Fasteners must be installed perpendicular to the board face, ie. do not skew fix
- Screw down with low torque, take particular care at ends of the boards
- Ensure the head of the screw finishes flush with board surface
- Fasteners in low corrosion areas should have galvanised coating or equivalent. In high corrosion areas stainless steel fasteners are recommended.
- Use only fixings which comply with New Zealand Standards
- *ModWood* must not be used as part of the frame or used as a structural element.
- 12 gauge screws may be used on 137 mm boards only. Fasteners must not be located closer than 20 mm from board ends. This will necessitate double joists or laminating a block on those joists where end butt joints will be located

Concealed Fixing with KlevaKlip

It is critical that the correct model of *KlevaKlip* is used with the chosen *ModWood* board. The Natural Grain Collection of solid boards have grooves on each edge and suit the following *KlevaKlip* models.



137 mm with groove on edge Non Powder Coated

KT137G Top Fix Clip Galvanised
KT137S Top Fix Clip S/Steel

137 mm with groove on edge Powder Coated

KT137GPC Top Fix Clip Galvanised
KT137SPC Top Fix Clip S/Steel

Please refer to www.klevaklip.com.au for fixing details and adhesive instructions.

ModWood Decking Fixing Instructions over concrete

Refer to website for specific instructions on decking applications over concrete.



The Sustainable Alternative

Fixing Instructions for ModWood

Refer to separate Flame Shield® fixing instructions when installing Flame Shield

Storage and handling

Store *ModWood* in a flat, dry area under roof and off the ground. Always carry *ModWood* on edge.

Ventilation

Good ventilation for your deck is essential. Check our chart for ground clearance information. Do not seal off deck ends, preventing airflow, including garden beds, trees or solid objects.

Installation

Fixings must not be closer than 15 mm from the end of the board and do not skew fasten. Double fix on each joist.

Fasten 20 mm from outside edge of the board. You can also fasten the 88mm decking boards using one screw/nail per joist in a zig zag pattern - see diagram (you will still need to fasten two screws/nails on the ends of each board). When butt joining top fix boards it is recommended to have 45 mm joists. Do not create a seam of joints.

Screw fixing

Pre-drilling and countersinking is essential when fixing with screws. Drill-bits used must be of at least the outside diameter of the screw thread (preferably slightly oversize). We recommend as a minimum, galvanised coated screws for low corrosion areas and stainless steel screws for high corrosion areas. Screw down with low to medium torque. Do not 'overdrive' screws, particularly near the ends of the boards. Screw should finish 'flush' with top of board.

Nail Guns

Should you decide to use a nail gun, you need to satisfy yourself that nail penetration and retention is satisfactory. Such tests should be carried out prior to installation. As with all decking, we believe the preferred methods of fixing are drill and screw, or drill and nail. Our preferred nail gun is the Paslode Duo-Fast CNP 65 Coil Nailer. Use dome head stainless steel decking nails. Double fix on each joist. We do not recommend nail guns for use on decking greater than 23 mm thickness, nor for use on steel joists.

Pre-drilling and hand nailing is essential when fixing boards by nail gun within 50 mm of end of the board.

ModWood Fixing Specifications

	decking solid (mm)	decking wide (mm)	marina board solid (mm)
Dimensions	88 x 23 mm	137 x 23 mm	137 x 32 mm
A minimum ground clearance	300	300	300
A minimum clearance over concrete	50	50	50
B joist centres (max distance)	450	450	600**
C minimum end-gap (butt join)	2	2	2
D minimum gap - side by side	4	4	6
E minimum distance from edge of board for fixing	20	20	20
F minimum end-gap to solid structure	6	6	6
screws (pre-drill and countersink)	yes	yes	yes
dome-head nails (pre-drill)	yes	yes	yes
nail gun acceptability*	yes	yes	no
suitability for fixing to steel structure	refer to website	refer to website	refer to website
fixing over concrete	refer to website	refer to website	refer to website

* - Use only dome-head nails from "coil-nail" gun. Pre-drill and hand nail when within 50 mm of end board. Not our preferred fixing method.

** - 450 mm centres for commercial applications.

In all cases, when screwing down do not overdrive screws. Fix with low to medium torque. Do not punch nail-heads under surface of board. Fixing too close to the end of the board will cause splitting. DO NOT fix within 15 mm of end of board.

Nail fixing

Pre-drill with a drill-bit large enough to provide a slight clearance on the hole, then fix with a dome-head galvanised nail. Do not punch the nail heads under the surface. In high corrosion areas, we recommend stainless steel decking nails (pre-drilling clearance hole still required).

Concealed Fixing with ModWood

KlevaKlip is the preferred method of using concealed fixing with *ModWood*. For all information on *KlevaKlip*, please contact www.klevaklip.com.au.

Please note that when using concealed fixing products, it is still important to ensure that the *ModWood* standard gapping spacing's for side-by-side, butt-joints and end spacing's are still strictly adhered to.

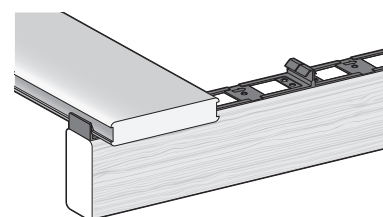

Important. Please check you use the right model *KlevaKlip* to fit the right model of *ModWood*. Refer overleaf.

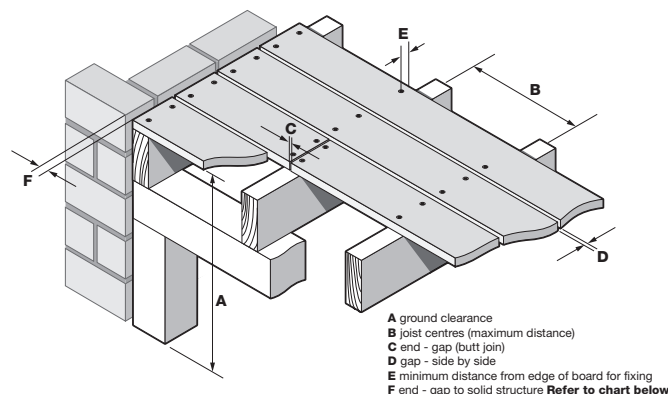

MODWOOD

decking

The Sustainable Alternative

ModWood Thermal Expansion Properties - Fixing tip

The temperature of a *ModWood* board sitting in full sun on a warm to hot day for a length of time is approximately 20-25°C warmer than the ambient air temperature.

As *ModWood* expands in heat and sun, to avoid building stress into your deck and having possible length ways shrinkage, it is best to fix your decking boards when the ambient temperature is less than 25°C and when the boards are not sitting in full sun (see 'coefficient of thermal linear expansion' on our website).

ModWood Decking Spacers

ModWood decking spacers, as seen below, have been developed to make your installation easier and in line with *ModWood* fixing instructions.

Note. Every pack of *ModWood* comes with 10 free spacers (used as strapping holders on the corners of full packs)

Extra spacers are available from your local *ModWood* retailer, or by contacting the *ModWood* distributor in your state.

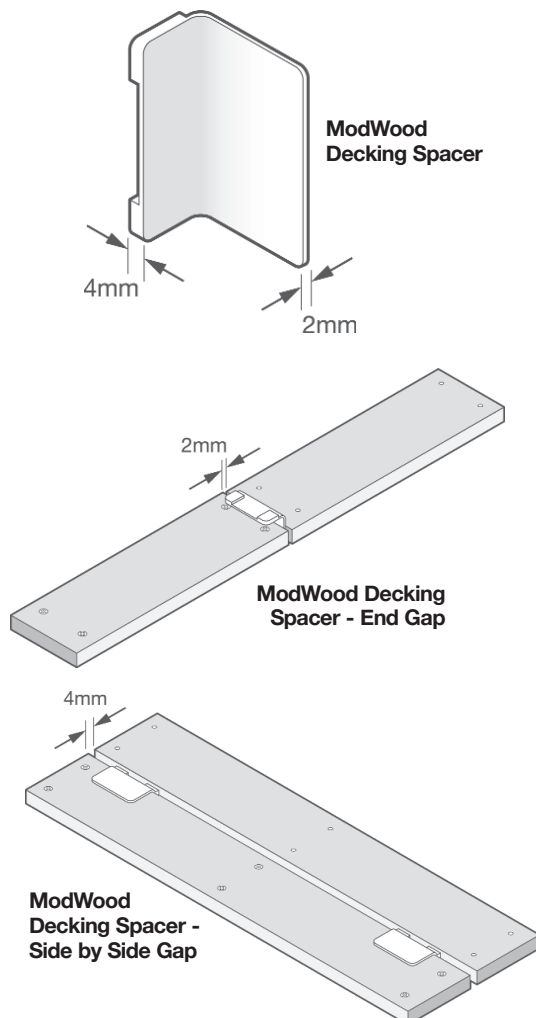

Typical Fastenings used with ModWood

Up to 23mm thickness boards

Fixing with timber - 8G-10 x 50 mm countersunk head screws
- 2.8 x 50 mm dome head twist shank nails

Nail guns - C2.5 x 52 Dome R SS Coil nails (Ring shank for softwood joists)
- C2.5 x 52 Dome S SS Coil Nails (Screw shank for hardwood Joists)

Fixing to steel - 10G-10 x 40 mm SDS (Self tapping tek) screws - non wing tek

Over 23mm thickness boards

Fixing to timber - 10G-8 x 65 mm countersunk head screw
- 2.8mm x 65 mm dome head twist shank nails

Fixing to steel - 10G-10 x 50 mm SDS (Self Tapping Tek) screws - non wing tek

General:

- Pre-drilling and countersinking is essential
- Fixing too close to board end will cause splitting - no closer than 15 mm and no closer than 20 mm from edge. Do not overdrive fasteners
- The hole drilled must be slightly greater than the 'outside diameter of the screw thread or nail shank
- Fasteners must be installed perpendicular to the board, ie. do not skew fix
- Screw down with low torque, take particular care at ends of the boards
- Ensure the head of the screw finishes flush with board surface
- Fasteners in low corrosion areas should have galvanised coating or equivalent. In high corrosion areas we recommend stainless steel fasteners
- Use only fixings which comply with New Zealand Standards
- *ModWood* must not be used as part of the frame or used as a structural element
- 12 gauge screws may be used on 137 mm boards only. Fasteners must not be located closer than 20 mm from board ends. This will necessitate double joist or laminating a block on these joists where end butt joints will be located

Concealed Fixing with KlevaKlip

It is critical that the correct model of *KlevaKlip* is used with the right model of *ModWood*.

The Natural Grain Collection of boards have a groove on edge and suit the following *KlevaKlip* models.

88 mm with groove on edge 137 mm with groove on edge
 KT88G Top Fix Clip Galvanised KT 137G Top Fix Clip Galvanised
 KT88S Top Fix Clip S/Steel KT137S Top Fix Clip S/Steel
 KSL88N KSL137N

Please refer to www.klevaklip.com.au for fixing details and adhesive instructions.

ModWood Decking Fixing Instructions Over Concrete

Refer to website for specific instructions on decking applications over concrete.

ModWood Screening Fixing Instructions

Refer to website for specific instructions on fencing and screening applications.