

Fixing instructions for ModWood

Refer to separate Flame Shield Fixing Instructions when installing Flame Shield.

Storage and handling

Store ModWood in a flat, dry area under roof and off the ground. Always carry ModWood on edge.

Ventilation

Good ventilation for your deck is essential. Check our chart for ground clearance information. Do not seal off deck ends, preventing airflow, including garden beds, trees or solid objects.

Installation

For deck areas partially under roof/cover, the brushed (lighter side)

MUST face up. For fully exposed areas; either face can be used. Fixings must not be closer than 15mm from the end of the board and do not skew fasten. Double fix on each joist. Fasten 20mm from outside edge of the board. When butt joining top fix boards it is recommended to have 45mm joists. Do not create a seam of joints.

Screw fixing

Pre-drilling and countersinking is essential when fixing with screws. Drill-bits used must be of at least the outside diameter of the screw thread (preferably slightly oversize). We recommend as a minimum, galvanised coated screws for low corrosion areas and stainless steel screws for high corrosion areas. Screw down with low to medium torque. Do not 'overdrive' screws, particularly near the ends of the boards. Screw should finish 'flush' with top of board.

Nail Guns

Should you decide to use a nail gun, you need to satisfy yourself that nail penetration and retention is satisfactory. Such tests should be carried out prior to installation. As with all decking, we believe the preferred methods of fixing are drill and screw, or drill and nail. Our preferred nail gun is the Paslode Duo-Fast CNP 65 Coil Nailer. Use dome head stainless steel decking nails. Double fix on each joist. We do not recommend nail guns for use on decking greater than 23mm thickness, nor for use on steel joists.

Pre-drilling and hand nailing is essential when fixing boards by nail gun within 50mm of end of the board.

ModWood fixing specifications

Dimensions		decking solid (mm)	decking wide (mm)	marina board solid (mm)
		88 x 23 mm	137 x 23 mm	137 x 32 mm
A	Minimum ground clearance	300	300	300
A	Minimum clearance over concrete	50	50	50
B	joist centres (max distance)	450**	450**	600**
C	minimum end-gap (butt join)	2	2	2
D	minimum gap - side by side	4	4	6
E	minimum distance from edge of board for fixing	20	20	20
F	minimum end-gap to solid structure	6	6	6
	screws (pre-drill and countersunk)	yes	yes	yes
	dome-head nails (pre-drill)	yes	yes	yes
	nail gun acceptability*	yes	yes	no
	suitability for fixing to steel substructures	refer to website	refer to website	refer to website
	fixing over concrete	refer to website	refer to website	refer to website
	suitability for commercial applications	no	yes	yes

* - use only dome-headed nails from "coil-nail" gun. Pre-drill and hand nail when within 50mm of end of board. Not our preferred fixing method.

** - depending on concentrated load (kN) this may be reduced. Contact ModWood directly for deflection calculation.

In all cases, when screwing down do not overdrive screws. Fix with low to medium torque. Do not punch nail-heads under surface of board. Fixing too close to the end of the board will cause splitting. DO NOT fix within 15mm of end of board.

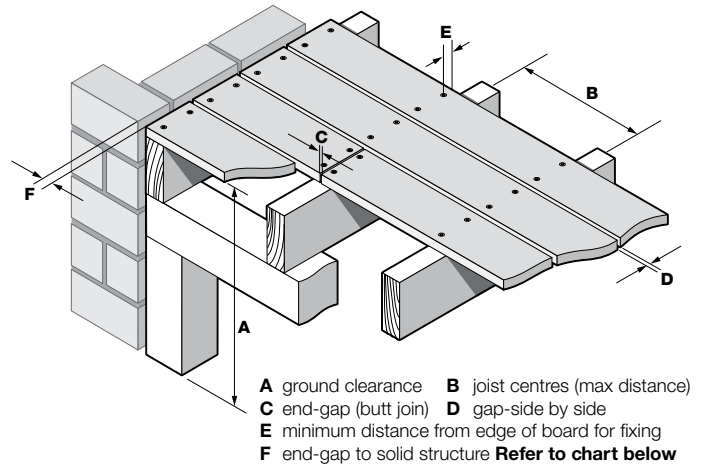

Concealed fixing with ModWood

KlevaKlip is the preferred method of using concealed fixing with ModWood. For all information on KlevaKlip, please contact www.klevaklip.com.au

Please note that when using concealed fixing products, it is still important to ensure that the ModWood standard gapping spacing's for side-by-side, butt-joints and end spacing's are still strictly adhered to.

Important please check you use the right model KlevaKlip to fit the right model of ModWood. Refer overleaf.

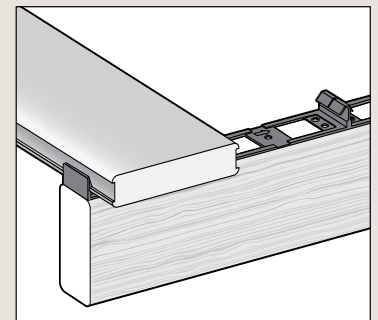

ModWood thermal expansion properties - fixing tip

The temperature of a ModWood board sitting in full sun on a warm to hot day for a length of time is approx. 20-25°C warmer than the ambient temperature.

As ModWood expands in heat and sun, to avoid building stress into your

deck and having possible lengthways shrinkage, it is best to fix your decking boards when the ambient temperature is less than 25°C and when the boards are not sitting in full sun (see 'coefficient of thermal linear expansion' on our website).

ModWood decking spacers

ModWood decking spacers, as seen below, have been developed to make your installation easier and in line with ModWood fixing instructions.

Note: Every pack of ModWood comes with 10 free spacers (used as

strapping holders on the corner of full packs). Extra spacers are available from your local ModWood retailer, or by contacting the ModWood distributor in your state.

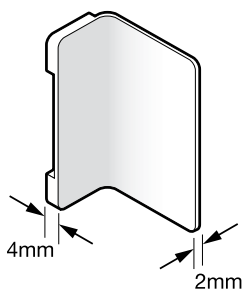

ModWood Decking Spacer

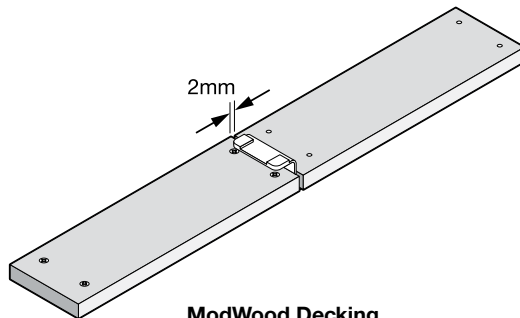

ModWood Decking Spacer - End Gap

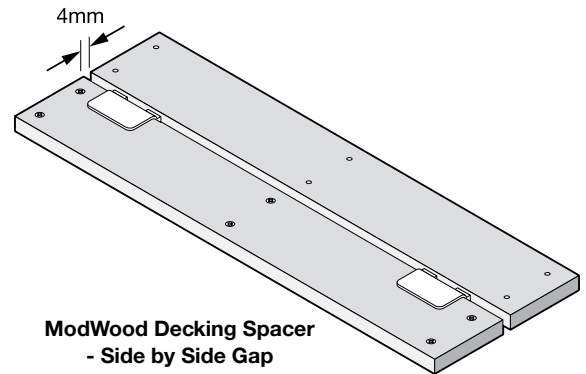

ModWood Decking Spacer - Side by Side Gap

Typical Fastenings used with ModWood

Up to 23mm thickness boards

Fixing to timber - 8 gauge x 50mm countersunk head screws
- 2.8mm x 50mm dome head twist shank nails

Nail guns

- C2.5 x 52 Dome R SS Coil Nails
(Ring shank for softwood joists)
- C2.5 x 52 Dome S SS Coil Nails
(Screw shank for hardwood joists)

Fixing to steel - 10 gauge x 40mm self tapping 'tek' screws

Over 23mm thickness boards

Fixing to timber - 10 gauge x 65mm countersunk head screws
- 2.8mm x 65mm dome head twist shank nails

Fixing to steel - 10 gauge x 50mm self tapping 'tek' screws

General:

- **Pre-drilling and countersinking is essential**
- **Fixing too close to board end will cause splitting - no closer than 15mm and no closer than 20mm from edge. Do not overdrive fasteners.**

- The pilot hole drilled must be slightly greater than the 'outside diameter' of the screw thread or nail shank.
- Fasteners must be installed perpendicular to the board face, ie. do not skew fix.
- Screw down with low torque, take particular care at ends of the boards.
- Ensure the head of the screw finishes flush with board surface.
- Fasteners in low corrosion areas should have galvanised coating or equivalent. In high corrosion areas use stainless steel fasteners.
- Use only fixings which comply with Australian Standards.
- ModWood must not be used as part of the frame or used as a structural element.
- 12 gauge screws may be used on 137mm boards only. Fasteners must not be located closer than 20mm from board ends. This will necessitate double joist or laminating a block on these joists where end butt joints will be located.

Concealed fixing with KlevaKlip

It is critical that the correct model of KlevaKlip is used with the right model of ModWood. The Natural Grain Collection of boards have a groove on edge and suit the following KlevaKlip models. Note: KSL88N, KSL137N or stainless steel clips must be used around pools and within 1km of salt water.



88mm with groove on edge
KT88G Top Fix Clip Galvanised
KT88S Top Fix Clip S/Steel
KT88GPC, KSL88N

137mm with groove on edge
KT137G Top Fix Clip Galvanised
KT137S Top Fix Clip S/Steel
KT137GPC, KSL137N

Please refer to www.klevaklip.com.au for fixing details and adhesive instructions.

ModWood decking fixing instructions over concrete

Refer to website for specific instructions on decking applications over concrete.

ModWood screening fixing instructions

Refer to website for specific instructions on fencing and screening applications.